

INTERNATIONAL JOURNAL OF ENGINEERING SCIENCES & MANAGEMENT

A STUDY TO PROVIDE PROTECTION TO VEHICLES FROM THEFT AND ACCIDENTS

Prabal Deep Das*¹ & Mrs. Sharmila Sengupta²
*^{1&2}V.E.S.I.T., Chembur (Mumbai), Maharashtra, India

ABSTRACT

Being India as one of the country having the highest number of reports filed for the occurrence of road accidents and car thefts; it has become a very serious issue which should get resolved as soon as possible. Thus, it is required to provide a cumulative system which will help the driver or the owner to make his vehicles protected from different fatalities and thefts. This paper has taken a step to provide various features of safety and security to the vehicle, as well as incorporating these features into a single system by using Raspberry Pi which is the heart of this system. This paper has mainly highlighted the system to provide protection from accidents using Bluetooth technology for communication purpose and sensors for detection purpose, whereas processing of Fingerprint image has been used to provide security to the vehicles.

Keywords: Bluetooth • Camera • Anti Lock Braking System • Sensor Fingerprint Recognition • MATLAB

I. INTRODUCTION

India is presently among the countries having largest number of cases reported on road accidents as it has been observed that in India around four injuries and more than one death occurs in every minute due to road accidents. This has created an alarming situation for the automobile industries to implement a system which will help in to provide both safety as well as security to the vehicles.

The word Safety means to provide protection to any object from getting damaged or affected through external means, thus in case of vehicles safety means to protect it from different accidents. There are many accessories which have been commercially implemented by the automobile companies for example Anti Lock Braking System, Lane Keep Assist System, Lane Departure Warning System, etc. There are other devices which have a greater scope in providing a good safety feature like in [1] the pre-collision alerts can be made by using Bluetooth technology implanted in the vehicles. The Bluetooth has been used for providing a temporary wireless connectivity with more than one vehicle at a faster rate. Similar communication system can also be used such as Zigbee Technology which provides alerting message to the nearby police station when the driver is performing a Rash Driving [4]. The communication systems has to be operated along with the sensors for fetching the information of the various parameters for example pressure provided on the accelerator and brakes [4]. These sensors will also help in detecting that weather the driver has consumed alcohol or not and according to that will cut off the fuel flow to the main engine [2]. The performance of Collision Alerting system using Bluetooth technology can be enhanced by interfacing the Bluetooth with Steering Control System which will automatically steer the wheels of the car in a particular direction [5]. This type of system requires internal communication which can be enabled by using CAN BUS which is used to provide a serial communication within the various systems of the car [6]. Apart from these, it is also possible to provide a feature which will provide protection to the life of a child or an elderly or a disabled person who get locked in the car and may die due to suffocation or heat stroke [3].

The word Security means to avoid the access of an object by any unauthorised person. In case of vehicles, it is completely dedicated to provide protection from or to avoid car burglary cases. There are many methods available to provide protection to the vehicles such as by having some manual locking system or by providing a device which will provide access to the person if and only if the person is authorized to access the car otherwise it will not allow him/her to drive the car. The identification can be done by having a biometric authentication system [7] and [8].

II. PROPOSED SYSTEMS

By using the already available mechanism or devices some of the safety and security features have been proposed in this paper which will enable the driver to protect their vehicle from getting damaged due to accidents and also from getting stolen.

Proposed Safety Features

The safety features which will be proposed in the following section will be assembled together with the Raspberry Pi module so that the signal from one system to another can be done simultaneously and also automatically at a faster rate. Pictorial descriptions of the various features have been shown below.

Bluetooth Enabled Collision Warning System will help in detecting the existence of any car within a distance of 10m using Bluetooth and will calculate the distance between the two adjacent cars or any vehicles by using an ultrasonic sensor. If the distance comes out to be less than the threshold value then depending on the distance the computer will send the signal to the antilock braking system (ABS) or Automatic Steering Control System. The whole process has been explained in figure 1.

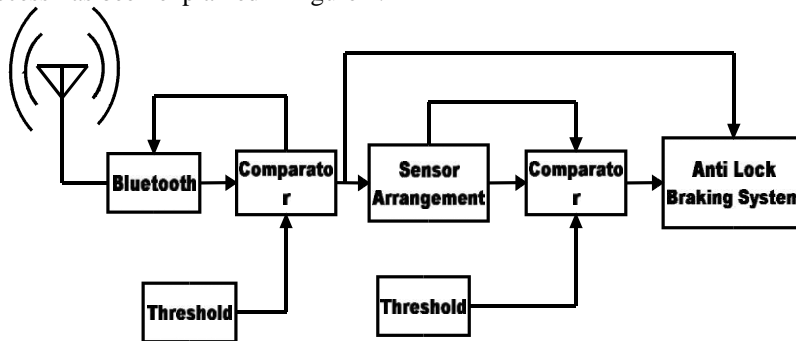

Fig. 1. Signal Flow Diagram of Bluetooth Enabled Collision

Hill Mode is mainly used to provide an efficient driving in an elevated plane or in hilly areas. It takes the input from an accelerator as well as a switch or from an altitude sensor for enabling the device to lock the reverse gear or activates the brakes of the car, so that when the user will try to climb up or move down along the sloppy regions it will help in providing the brakes to the car when the accelerator is not applied which has been shown in figure 2.

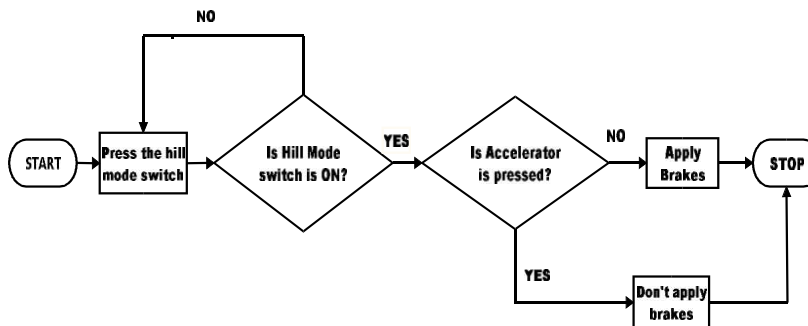

Fig. 2. Flow chart of Hill Mode

Child in Car Alerting System gets enabled when the car engine is OFF and a person or a child (who is not able to get out from the car without the help of any another person.) is present in the car. The sensor will start sensing the temperature within the car and accordingly it will perform immediate operations to maintain the temperature of the car to remain within the prescribed range and if the temperature goes beyond that range then it will alert to the main owner through GSM as well as it will start ringing the alarm. The system operation is explained in Figure 3.

Rash Driving Alerting System will help in avoiding the accidents caused by rash driving. The rash driving can be sensed by determining the number of times the driver is applying brakes and acceleration in a given period of time.

This device will sense for the occurrence of rash driving in both types of traffic conditions. It will warn the driver by sending the alert message in the first iteration using GSM module and in the second iteration, if the same procedure occurs then it will provide the message to an Accident Prevention Unit (APU) which will forward the information of the car and its owner to the nearby police station which can better understood from Figure 4.

Drunken Driving Alerting System will sense the presence of vapours in air which has been breathed out by the driver who has consumed alcohol. If the alcohol content in air becomes greater than the threshold then a text message is send to all the nearby cars coming within the range of the Bluetooth send to its driver’s phone using GSM module. In the next iteration the ABS comes into the play and the nearby police station receives the information of the car and its owner via ACU.. Its complete flow diagram is given in Figure 5.

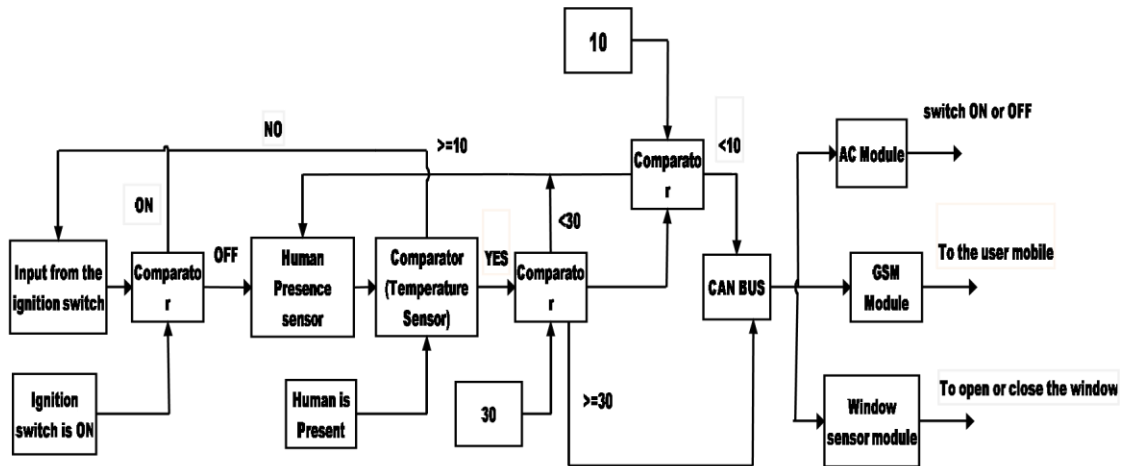

Fig. 3.Signal Flow Diagram of Child in Car Alerting System

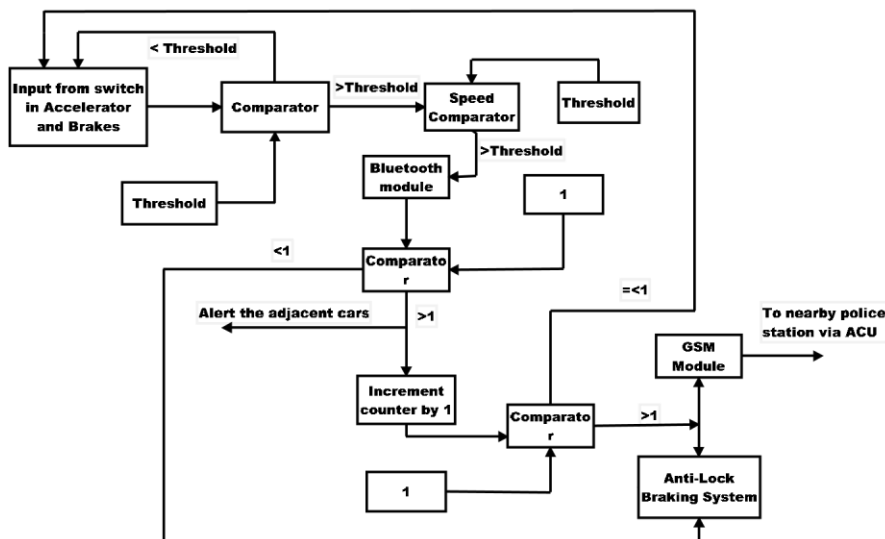

Fig. 4.Signal flow diagram of Rash Driving Alerting System

Automatic Road Sign Monitoring System will automatically look the presence of road signs and will perform the immediate operation. This feature has been implemented to prevent collision with a pedestrians or to avoid collision in busy traffic areas. The principle operation has been explained in Figure 6.

Proposed Security Feature

The security to the car can be provided by using fingerprint recognition system because in [8] a comparison was made between all the biometric methods. Among these fingerprint recognition system came out to be more reliable in all the parameters of comparison. Thus it will be assembled to Raspberry pi for its centralised use.

Fingerprint Based Start/Stop Touch Switch gets enabled when the owner of the car will unlock its (car) door using IR sensor. This will ensure that without owner’s authentication the car’s ACC will not be unlocked and thus, your car will also not start. It has been adopted as an alternative to key lock system in car. The complete flowchart is given in figure 7.

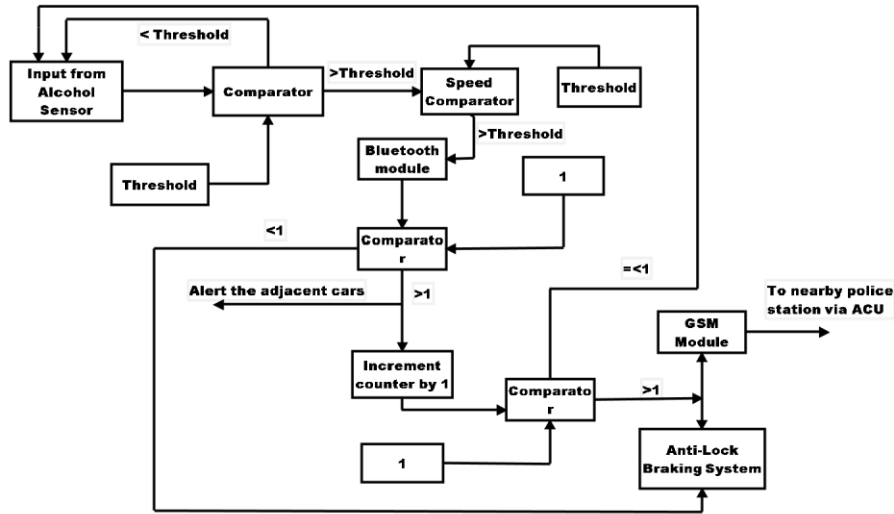

Fig. 5.Signal flow diagram of Drunken Driving Alerting System

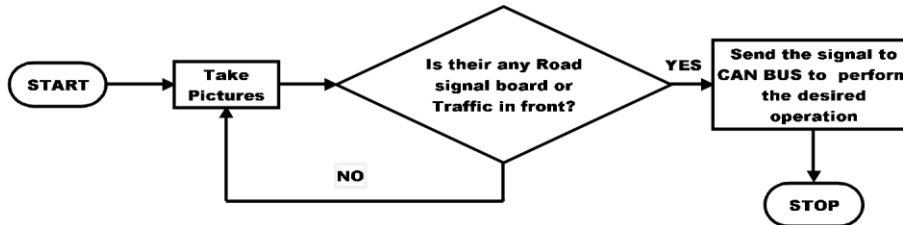

Fig. 6.Signal flow diagram of Automatic Road Sign monitoring system

III. EXPERIMENTAL SETUP

The features mentioned above have been assembled together, so that it can be used in a vehicle as a single device. The components were assembled together and are being controlled by using Raspberry pi. In this case Raspberry pi B model has been used because it is having around 32 GPIO pins which exactly satisfy the need of this system. The overall architecture of the system has been explained in Figure 8 in which the dotted lines are indicating the signal flow.

IV. RESULT

The various features were tested by programming in C language in MATLAB. The algorithms required to implement the following features along with the circuit diagram of some features are given below.

Bluetooth Enabled Collision Warning System

This feature requires eight sensors arranged in a manner to receive the signal of vehicle in one of the eight different directions. These sensors will get activated as soon as Bluetooth will sense the existence of any vehicle coming in the range of 10m. The circuit diagram of Sensor arrangement is given in Figure 9 The algorithm for this feature is:

- Activate the Bluetooth module connected as a USB in Raspberry Pi.
- Connect with the adjacent cars if any.

- If connection is successful, then activate the sensor arrangement.
- The sensors will detect the exact location of the car and will give the control signal to the Automatic Steering Control System or Anti-Lock Braking System.
- If the number of cars is greater than or equal to three, then it will automatically stop the car.

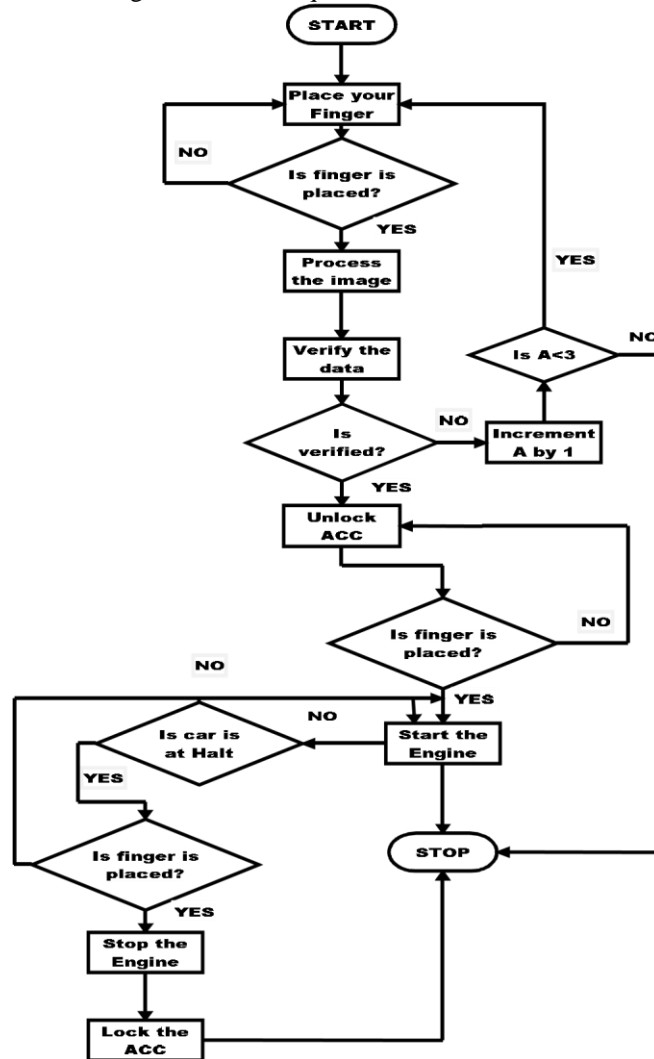

Fig. 7. Flow chart of Fingerprint based start/stop Touch Switch

Hill Mode

To make this feature operational, an altitude sensor is used to detect the elevated region automatically and will start working in the following way

- If altitude sensor senses the occurrence of elevation enable the input to the Raspberry Pi.
- Fetch the input from touch switch placed on the accelerator and consider it as another input.
- If the accelerator has been pressed, the processor will disable the Brakes applied through ABS and vice versa.

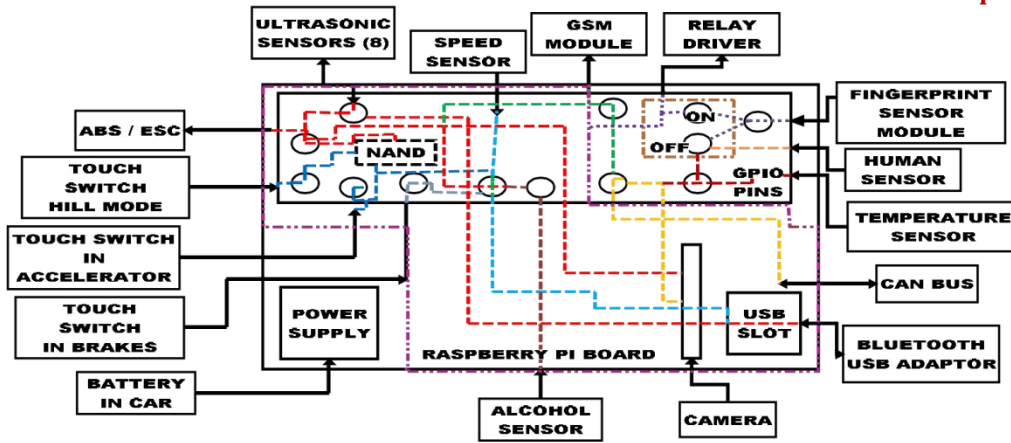

Fig. 8. General Architecture of the proposed system using RASPBERRY PI Board

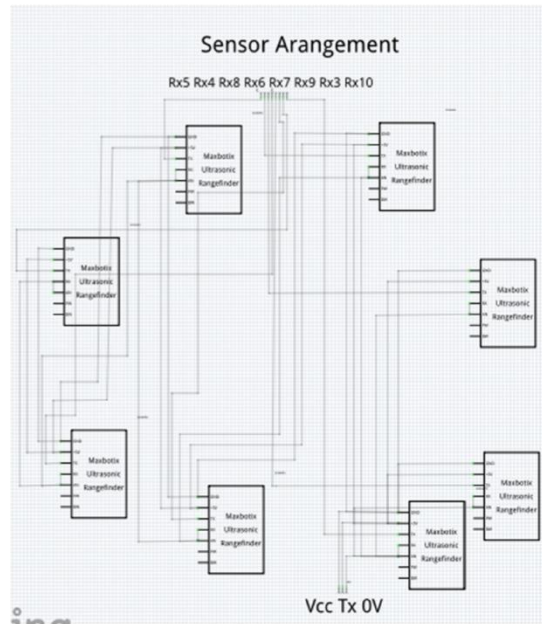

Fig. 9. Circuit Diagram of Sensor Arrangement

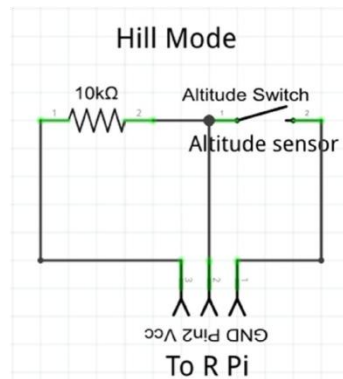

Fig. 10. Circuit diagram for interfacing Altitude sensor for Hill Mode

Child In Car Alerting System

In this feature a human presence thermal sensor is used (D6T Omron Switch). The signal will flow in the following manner.

- Check whether the car is OFF or not.
- If OFF then sense for the presence of any human or any animal inside the car.
- If temperature is greater than 30°C or less than 15°C then send an alerting message to the driver If YES then enable the temperature sensor to sense the temperature inside the car.
- If temperature is greater than 27° C then windows will be closed and AC will be switched ON. via GSM module and enable the buzzer to ring.
- If temperature is less than 20° C then windows will open and AC will be switched OFF.

Drunken Driving Alerting System

It uses IR sensor for detecting the alcohol content in air. The transmitter and receiver of the same have been given in figure 11 (a) and (b). The algorithm is as follows:

- Check for the alcohol content in terms of intensity of light being received by the IR receiver.
- If the intensity is less than threshold, then give the signal to activate Bluetooth to broadcast the alert message to the cars adjacent to the affected car.
- It will also make the car to halt by using ABS system.
- Simultaneously give the message to APU via GPS module and give the information of the driver to the nearby police station.

Rash Driving Alerting System

It requires two touch switches which is to be implemented on both the accelerator as well as on the brakes. The circuit diagram of Touch switch has been given in figure 10, same will be used as an input for the Hill mode feature and the algorithm to detect the rash driving is as follows.

In Heavy Traffic

- Set the timer to 2msecs.
- Count the number of times the driver has pressed the accelerator and breaks within the given time (k).
- If K becomes greater than 4 then halt the vehicle and give the information to the nearby police station via GSM Module and ACU unit.

In no traffic

- Set the timer to 2msecs.
- Count the number of times the driver has pressed the accelerator and breaks within the given time (k).
- If number of brakes is less than 4 and accelerator count are greater than 4 then halt the vehicle and give the information to the nearby police station via GSM Module and ACU unit.

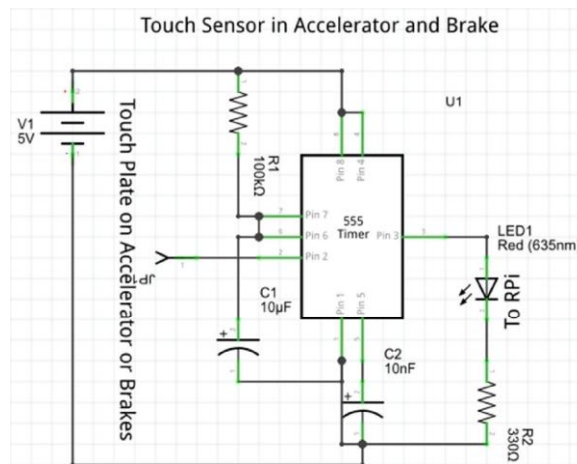

Fig. 10. Circuit Diagram of Touch Sensor or Switch in Accelerator or Brakes

Automatic Road Sign Monitoring System

It requires a camera which will start operating in the following manner.

- The camera will continuously take the Road-Side Image which will be processed by using different extraction models like extracting the color of the Border of the Road Sign by using YCbCr Model, or any other type of Color Model,
- The recognition of shape of the Road Sign (Triangle, Circle, Octagon) will be done by using Correlation Method and the Exact Road Sign is extracted by using the Combination of Bounding Box and Sobel Filter Method.
- The Filtering Method will help in to extract the road Sign throughout its border.
- The recognition will be done by using Neural Network.

Fingerprint Based Start/Stop Touch Switch

It requires a fingerprint sensor module which is to be interfaced with Raspberry Pi. The method of interfacing is shown in figure 12. The algorithm is given as.

- Activate the Fingerprint module by using an IR switch while unlocking the door.
- Scan your fingerprint on the module.
- If scan is successful then unlock the car by giving the signal to ACC via Relay switch. □ Again scan the finger to start the engine through the relay switch.

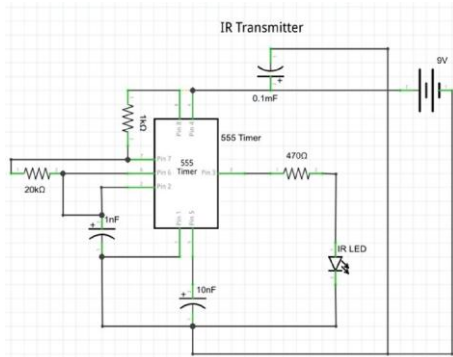

Fig. 11(a). Circuit Diagram of IR Transmitter

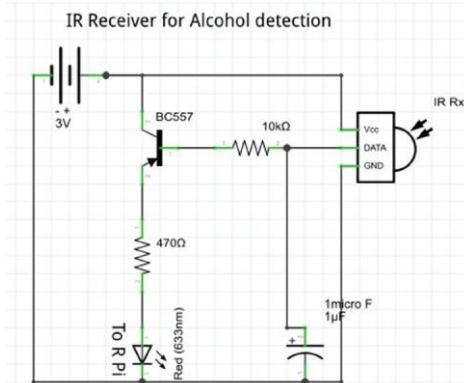

Fig. 11(b). Circuit Diagram of IR Receiver

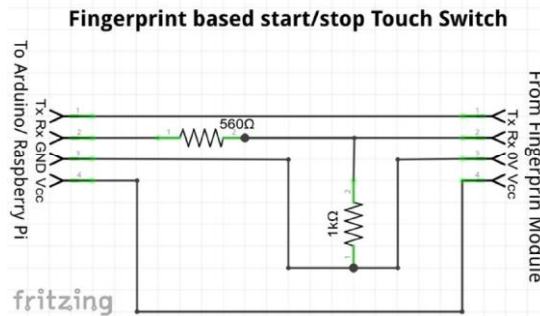

Fig. 12. Fingerprint Based Start/Stop Touch Switch

The components required implementing such features and their positions in a vehicle have been shown in the figure 13 below. The seventh component is the CAN BUS along with ECU module which is present in the car to provide the serial communication within the various modules of the car.

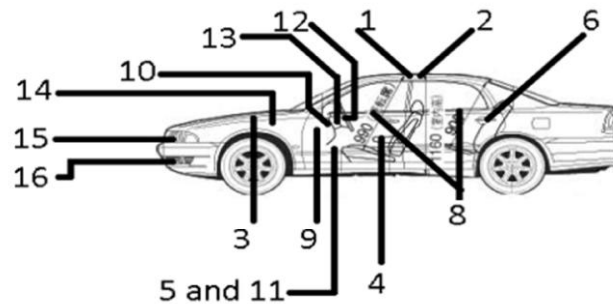

Fig. 13. Components mounted in a car

- | | |
|-------------------------------------|----------------------------------|
| 1. Bluetooth module | 10. Touch switch in Brakes |
| 2. Sensor Arrangement | 11. GSM Module |
| 3. Anti-Lock Braking System | 12. Sensor for alcohol detection |
| 4. Hill mode switch | 13. Fingerprint Module |
| 5. Touch switch in Accelerator Unit | 14. Relay module |
| 6. Human Presence Sensor | 15. Camera |
| 8. Window controlling unit | 16. Radar |
| 9. AC module controlling | |

V. CONCLUSIONS

The system to be proposed has been implemented having the following advantages like:

- Easy to interface and also easy availability of the components.
- Having maximum use of every component to be used in the above mentioned features in order to make a system simpler in terms of connectivity.
- The battery power usage by the components will be less thus providing the battery to retain its life to some extent.

Thus this system will help in to provide both safety as well as security to the vehicle in a more reliable manner in worst case environmental condition.

REFERENCES

1. Folasayo, Oyedemi Jacob, and Adekunle Salami. "Bluetooth technology: A global tool in communication industry for prevention of accidents." *Computer Science & Education (ICCSE), 2015 10th International Conference on. IEEE, 2015.*
2. Ramanath, T. Shyam, A. Sudharsan, and U. PelixUdhayaraj. "Drunken driving and rash driving prevention system." *Mechanical and Electrical Technology (ICMET), 2010 2nd International Conference on. IEEE, 2010.*
3. Aiello, Vittoria, et al. "Next-generation technologies for preventing accidental death of children trapped in parked vehicles." *Information Reuse and Integration (IRI), 2014 IEEE 15th International Conference on. IEEE, 2014.*
4. Rajesh, Madhumathi, and D. Muruganandam. "On proposing automobile accident prevention system (A2PS) using wireless sensors and zigbee technology." *Computing Communication & Networking Technologies (ICCCNT), 2012 Third International Conference on. IEEE, 2012.*
5. Hong, Tao, Xijun Zhao, and Yong Zhai. "Development of an Automatic Steering System for Electric Power Steering (EPS) System Using Fuzzy Control Theory." *Communication Systems and Information Technology. Springer Berlin Heidelberg, 2011. 179-186.*
6. Khurana, Prateek, RajkumarArora, and Manoj Kr Khurana. "Microcontroller based implementation of Electronic Stability Control for automobiles." *Advances in Engineering and Technology Research (ICAETR), 2014 International Conference on. IEEE, 2014.*
7. Yuan, Wui, and Songhua Tang. "The Driver Authentication Device Based on the Characteristics of Palm print and Palm Vein." *Hand-Based Biometrics (ICHB), 2011 International Conference on. IEEE, 2011.*
8. Jain, Anil K., Arun Ross, and SalilPrabhakar. "An introduction to biometric recognition." *Circuits and Systems for Video Technology, IEEE Transactions on 14.1 (2004): 4-20.*